

Climatica Dual WEATHER STATION Installation Instructions

Models: 352 0400 001 (miles/hr)
352 0400 002 (km/hr)
352 0400 003 (metres/sec)

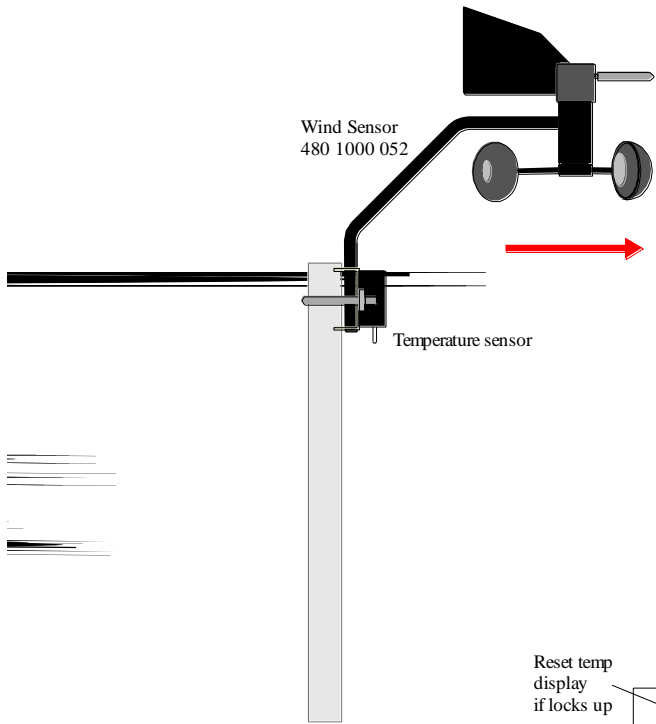

Wall mount by Key-hole slots in rear 350 mm centres

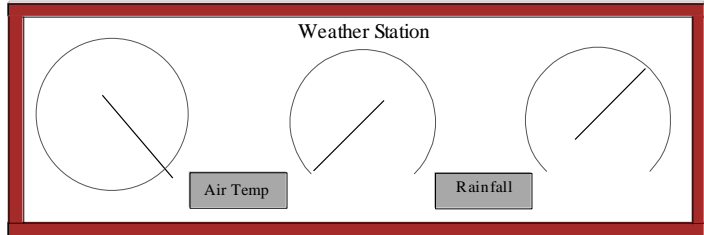

Reset temp display if locks up

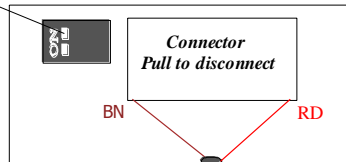

Use cable knock-outs in cabinet to bring cable away

Rear View

To Weather Station Display
12-core (5m Max.)

354 0000 001



To RS232 P.C. serial port
(100m Max.)

To MeT-LoG (if fitted)

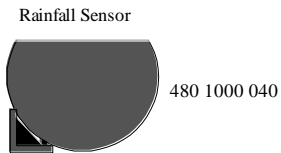

To Rain Sensor
(100m max)

To Wind Sensor
(100m max)

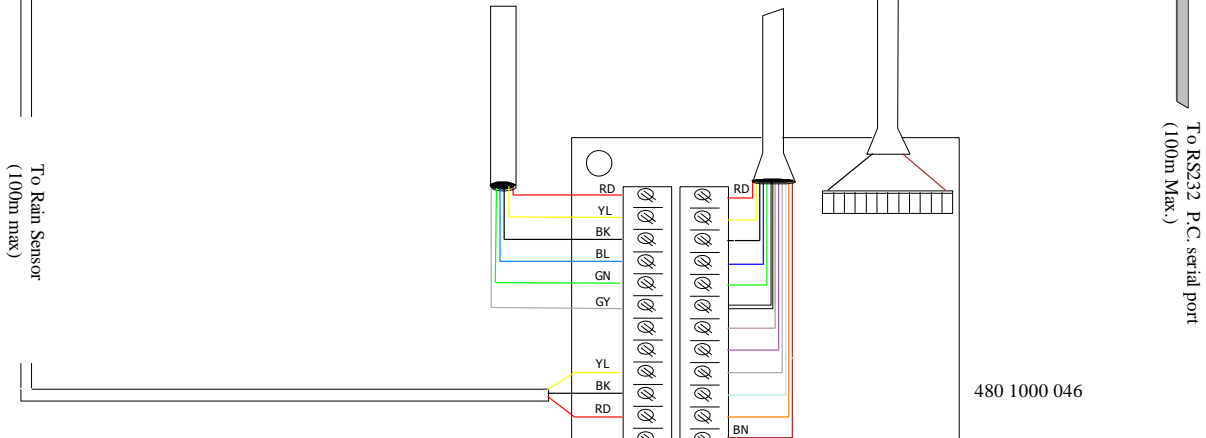

WEATHER STATION
can be powered by
12 Volts dc at approx. 150 mA
or 220-240 Volts ac 50Hz
Nb. Pre-wired for 220-240V ac operation

12 volt DC supply
or Battery backup

**JUNCTION BOX
&
POWERSUPPLY**

0.5 A fuse
for
12 V supply

230 Volts AC Supply
FUSE 2A max

**** WARNING ****
Disconnect mains supply
before removing lid

RAIN SENSOR INSTALLATION INSTRUCTIONS

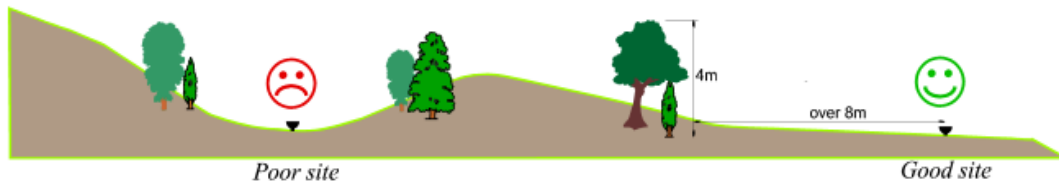

The Rain Sensor should, ideally, be situated at a distance of twice the height of local obstructions and mounted 30cm (12") above ground level. This requirement can often be difficult or impossible to achieve due to surrounding bushes, trees etc. For most practical purposes accuracy will not be greatly impaired if the site is only a distance equal to the height of the obstructions.

It is important that the sensor is reasonably accessible as, from time to time, the filter will require cleaning. Very often the top of a fence post provides an excellent site so long as it is firm, clear of bushes and trees as above.

It is wise to avoid mounting on or near buildings which can cause wind turbulence and create dust. Avoid also mounting near to transmitter aerials which can in certain circumstances cause interference.

Installation

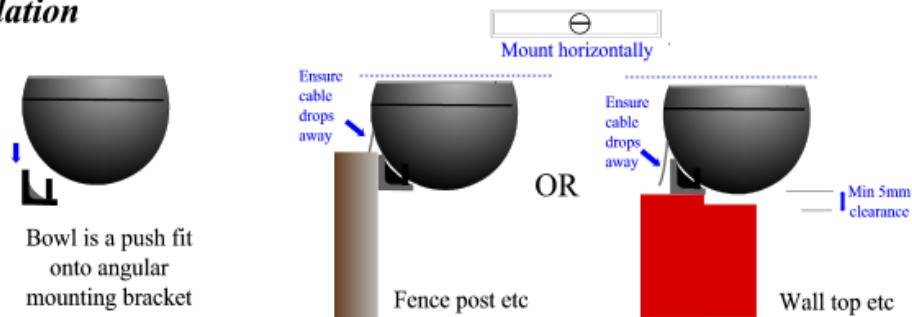

Screw the angular mounting bracket to a **firm and rigid** post, fence or wall ensuring that the funnel opening is absolutely horizontal. Ensure also there is at least **5mm clearance** between the **bottom of the bowl and any surface below**.

To avoid the possibility of water running down the cable into the sensor, it is important that the cable drops away from the bowl. Leave some slack in the cable beneath the sensor to facilitate cleaning.

Now lay out the cable to the control box avoiding close proximity to power and transmitter cables. Be very careful not to nick the cable when being clipped to walls etc. If the cable is to be buried run cable through plastic hose etc. to avoid vermin biting through cable.

Cable screen

Maintenance

From time to time dust and other foreign bodies will accumulate on the funnel filters.

To clean;- carefully withdraw filter and sponge and clean under a tap.

Important - avoid touching the stainless steel filter mesh with bare fingers as this will deposit grease which may impair the flow of water.



SPECIFICATION

Display unit size: 450 wide x 180mm high x 60mm deep

Display parameters:

Wind direction: Analogue read-out 4 cardinal points sub-divided into 5 degree increments, electronically damped.

Accuracy: ± 10 degrees, resolution > 10 degrees

Wind speed: Analogue read-out with gust indicator pointer, calibrated 0- 90 mph, 0-80 knots and Beaufort scale.

Alternative kph and metres/second scales are available (see Model Numbers on front sheet)

Accuracy: $\pm 5\%$ or 3 knots

Barometer: Analogue read-out with set pointer reset, range 950 -1050 mBar (28 -31 inches Hg)

Temperature: LCD digital read-out in degrees F or C, selectable via push buttons

Range - 40 to + 50° C (- 40 to + 120° F), resolution 0.1° C

Rainfall: LCD digital read-out in 0.01mm increments

Accuracy: $\pm 5\%$ (5ml of water = 1mm rainfall), resolution 0.01mm auto-sensing

SENSORS

Roof-mounted wind speed and direction sensor, temperature sensor with mounting clamps for easy installation on mast diameter 25 – 50mm. Remaining sensors wall or post mounted (see installation details with product)

Data cable length: 25m standard pre-wired (additional cable lengths are available when ordering).

Materials: sensor assemblies utilise anodised aluminium alloy, stainless steel, nylon, injection moulded polypropylene anemometer cups.

Compass provided to align wind sensor arm to North.

POWER SUPPLY

220 – 240Vac 50Hz or 110Vac 60Hz moulded plug-in power supply unit. Alternative 12Vdc may be Customer supplied.

OPTIONAL EXTRAS

Gust alarm: Audible alarm set to adjustable maximum

Wind speed x 2: Facility to double recording scale (used for exposed sites)

Met4Net 'S' Part No. 354 0000 001: Data logger to PC RS232 serial port connectivity or via USB serial port adaptor cable (separately purchased from Instromet Ltd. Part No. 269 1002 001)

Software: MeT-LoG 98 bespoke software for data recording (not compatible with Windows XP) only available while stocks last.

Met4Net™ bespoke software for data recording Part No. 356 0000 001.

Mounting Kits: Aluminium masts 36" long x 1½" diameter

Mast couplers for joining two masts i.e.6'

Wall bracket with mast clamps

} Part No. 480 1000 096

or Roof/slate mounted mast kit for non-chimney dwellings Part No. 480 1000 097

Autostation: Automatic Weather Station & Met4Net™ software Part No. 355 0000 001/002/003 for 240V/110V/220V respectively.



Installation Instructions

Weather Stations consist of a master display unit, a combined wind and temperature sensor connected by a six core cable, a rain sensor connected by a 4 core cable (only 3-cores used) and a separate junction box/power supply. (A separate temperature sensor mounted in a radiation screen can be supplied.)

Sensor wiring

The cables should be connected to the individual sensors via the terminal block on the sensor bracket. This can be accessed by removing the black cover, where a wiring identification label will be found.

Roof Top Wind/Temperature Sensor

This unit should be mounted on a mast of 25-50mm (1-2") diameter (suitable mast mounting solutions are available from Instromet sales), as high and as far away as possible from chimneys, roof peaks, buildings, trees and transmitter aerials which may cause wind turbulence or interference. Where possible the roof top wind sensor should be mounted at least 2 metres above roof peaks and be secured in position with the arm pointing accurately to the NORTH with the compass provided.

The cable from the roof top wind sensor should be run down to the junction box, making sure it is properly secured. Please note! This cable should not be run in close proximity to power or transmitter cables. If it is necessary to shorten the cable, please do this when connecting the cable to the display unit.

WARNING: Under no circumstances should the wind sensor junction box cover or the terminal block inside be sealed in any way as it is designed to breathe.

Junction Box & Power Supply

This unit allows the wiring from the sensors to be terminated away from the main display cabinet and a single multi-core cable to be wired to the display. Five metres (15 ft) of cable are supplied which may be shortened if required. Increasing its length may cause inaccuracies in the temperature read-outs.

To avoid water travelling down cables into the junction box it is important to ensure that the cables drop below the junction box at some point preferably in the form of a 'U' bend. This will allow any water travelling down the cables to drip off.

The mains power supply is wired to this unit and care should be taken to ensure that the correct fuse is used i.e. 2 - 5Amp.

Display Unit

The illuminated display unit should be wall mounted by the two key-hole slots in the back panel, 350mm centres. The cable may be either channelled into the wall or brought out the side of the cabinet by using the cable knock-out holes at each side and at the bottom of the cabinet. Please make sure no dust gets into the display unit.

The display unit is connected to the junction box by a 12 core cable fitted to a 12 way plug. When connecting please **ensure that the connector is the correct way round.**

Operating Instructions

Barometric Pressure

Calibration of the barometer is achieved by adjustment of the screw head on the barometer movement, accessible through a hole in the back panel.

Gust Pointer

Rotate the gust knob anti-clockwise until it connects with the wind speed pointer. It will now be carried up to show the maximum speed.

X2 Wind Speed (when fitted)

Press the middle button on the left of the cabinet to activate the x2 wind speed. The x2 lamp will illuminate and all subsequent readings of wind speed must be multiplied by two.

Gust Alarm (when fitted)

The small knob at the left of the cabinet is set to the speed (Beaufort scale) at which the alarm is sound. The alarm will turn off when the wind speed drops to approximately half the set speed.

Outside Temperature

The LCD temperature display shows the outside temperature at the roof top sensor. Celsius or Fahrenheit display may be selected by pressing the lowest of the buttons on the left side of the cabinet.

LCD Display

The LCD display has a back up battery to allow for accidental loss of power whilst still maintaining the records of temperature. Under normal usage the battery should last at least 2 years. Should the display reduce in contrast when the power is off, a replacement AA Alkaline battery is easily fitted by disconnecting the power supply and removing the back panel.

Should the LCD display lock up, i.e. numbers are fixed or strange, slide the switch at the rear of the display unit to OFF for 30 seconds, then slide back to ON. This should cure the problem. If not, repeat the operation.

Troubleshooting Guide.

You've installed your Weather Station and find that despite careful attention to detail, it does not work as expected. The following notes may assist in getting your Weather Station working.

Nothing appears to work.

Check that the power supply is turned on at the wall socket. Check power cable correctly wired to the correct terminals in the Junction Box. If the lamps inside the unit are illuminated then the power to the instrument is correctly wired and working.

Wind Direction wrong

If Wind Direction gives the wrong reading, check that the wind sensor has been mounted to point North. If the pointer is permanently displaying a Northerly or North

North East wind direction then the wind sensor is not connected to the instrument or is incorrectly wired. Note that if the wind sensor is incorrectly wired then neither wind speed nor direction will work.

Wind Speed not working

Check anemometer cups are turning freely and if so wiring is correct (particularly the *blue* wire from the Wind Sensor) and the cable not damaged.

Temperature display flashing LLL.

This indicates that the temperature probe is not connected to the instrument. Check that the *green and white* wires from the wind sensor are correctly connected to the appropriate terminals.

Temperature display locked on a fixed temperature.

The display may have locked up during installation. Other indications are that none of the buttons located at the side of the instrument will have any effect on the display. This can sometimes happen and can be corrected as follows:-

Remove the Display from the wall (if wall mounted), to the left of the connector there is a small slide switch with two white buttons, slide these to the right to the *off* position. Leave for one minute, during which time the display(s) should go blank. Now slide the switches to the ON position (to the left). If this procedure fails to cure the problem repeat the procedure once more, waiting a little longer before sliding the switches to the ON position.

Temperature reading inaccurate

If the temperature reading is only 1 or 2 degrees out then the display can be recalibrated as follows:-

Remove the display from the wall by lifting the unit and pulling forward.

At the back of the temperature display there is a small preset with a screw driver-slot visible beneath and to the left of the connector. Adjust this with a small screw-driver to give correct display.

If the cable to the Wind/Temperature has been extended, the accuracy of the temperature will be reduced, and although this can be adjusted as above, extremes of temperature may show other errors.

If temperature reading is very inaccurate, showing HHH or LLL, check wiring to the junction box (usually *white & green* wires see installation instructions) and cable.

Barometer showing incorrect pressure.

The barometer may need adjusting to the pressure at your location. First obtain a pressure reading from a reliable nearby source such as an airfield or local met office. Having done this locate the adjustment screw visible through the back panel and using a small screwdriver turn the adjusting screw until the pressure reading is the same as that obtained locally. Do not attempt to turn the screw more than one turn in either direction. If all fails call service department **01692 502800** or return the sensor to us for checking or replacement.

Instromet Ltd. (A Novomec Group company)

Lyngate Industrial Estate

North Walsham

Norfolk NR28 0AW

Tel: (01692) 502800 Fax: (01692) 502801

e-mail: sales@novomec-group.co.uk

Disclaimer

As part of our ongoing policy to improve the design and specification of our products, we reserve the right to change any detail given without prior notice. The Novomec Group shall not be responsible for any liability or loss of any nature which may result from the use of any information provided in technical literature. Instromet® products are designed to monitor current and previous weather conditions for domestic use and should not be considered as predictive weather forecasting equipment. Contact your regional Met Office centre if you need weather forecasting data (www.metoffice.gov.uk)

Our products are tested in-house for operation and functionality but have not been independently tested by a UKAS accredited laboratory.

